



UFLEX LIMITED MOLDING DIVISION

Doc. No. : UFL/FR/QA/063

Rev. No. : 00

Rev. Date : 01.10.2020

PRODUCT SPECIFICATION

Product : 10.5mm Cap & Without Channel Spout

Material Cap: PPCP

Part Weight Cap: 1.10± 0.10gm

Material Spout: HDPE

Part Weight Spout: 1.90± 0.15gm

Masterbatch %: As per Shade Requirement

Product Code Cap: CAPP-10.5

Product Code Spout : SPWC-10.5

Product Code Cap & Without Channel Spout Assembled: ASWC-10.5

Product Parameters

| S no. | Test Name | Parameter | Standard |
|-------|--|--|---|
| 1 | Cap Dimension Analysis | Cap Height | 18.80±0.15mm |
| | | Bottom Outer Diameter | Ø19.50±0.15mm |
| | | Cap ID | Ø14.20±0.05mm |
| 2 | Spout Dimension Analysis | Spout Width | Ø15.50±0.10mm |
| | | Inner Diameter | Ø10.50±0.10mm |
| | | Outer Diameter | Ø17.20±0.10mm |
| 3 | Tamper Evident Test (For Cap) | Tamper ring should Break | - |
| 4 | Leakage Test | Inspection Pressure: 0.25bar Inspection Pressure Tolerance: 0.05bar Filling time: 3 sec Stabilization Time: 3 sec Test time: 3 sec | Pressure Decay upto 70pa allowed |
| 5 | Thread Position Deviation Test (For Cap) | Cap to be tightened on Mandrel Guage till stops | ±20° |
| 6 | Packing | - | Cap-10000pcs per Box Spout-4500pcs per Box |

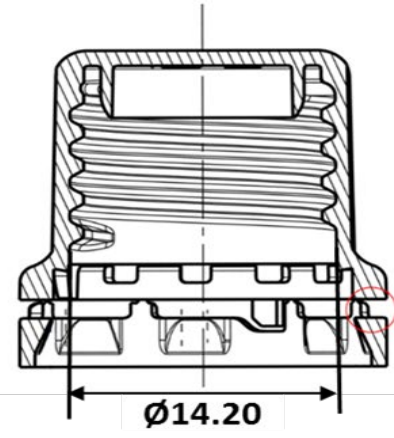
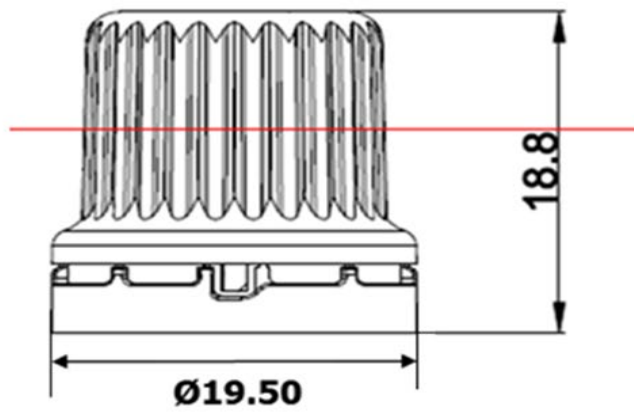

Cap 10.5mm

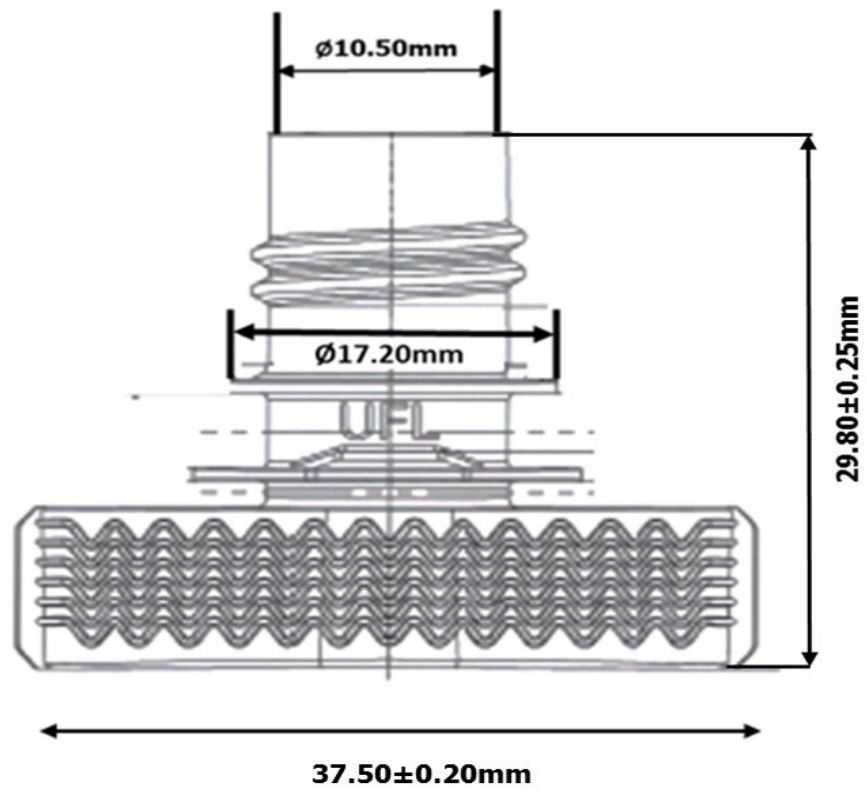

Without Channel Spout 10.5mm