



**UFLEX LIMITED
MOLDING DIVISION
PRODUCT SPECIFICATION**

Doc. No. : UFL/FR/QA/052
Rev. No. : 00
Rev. Date : 01.11.2019

Product 10.5mm Cap & Spout Assembled

Material Cap: PPCP

Part Weight: 3.36± 0.20gm

Material Spout: HDPE

Product Code Cap & Spout Assembled : ASSC-10.5

Masterbatch %: As per Shade Requirement

Product Parameters

S no.	Test Name	Parameter	Standard
1	Dimension Analysis	Total Height with Cap	35±0.5mm
		Spout Width	Ø16.10+0/-0.40mm
2	Tamper Evident Test	Tamper ring should Break	-
3	Leakage Test	Inspection Pressure: 0.25bar Inspection Pressure Tolerance: 0.05bar Filling time: 3 sec Stabilization Time: 3 sec Test time: 3 sec	Pressure Decay upto 70pa allowed
4	Packing	-	4500pcs per Box

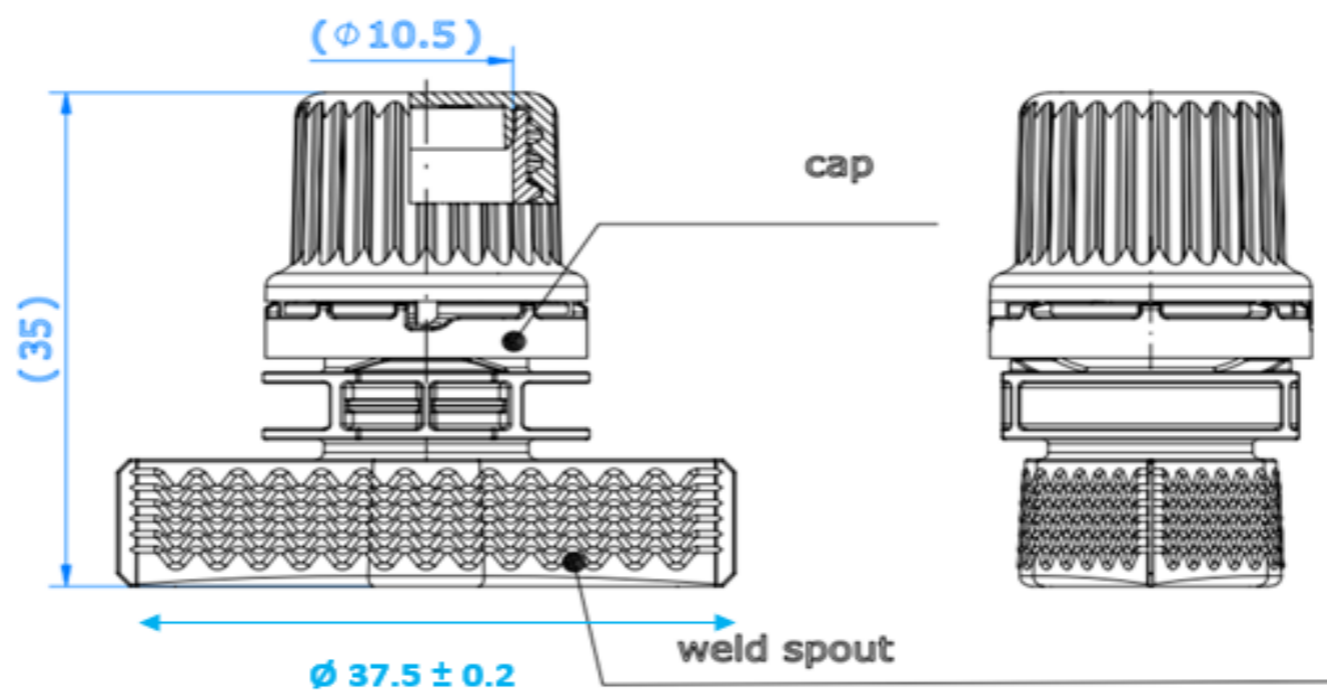



UFLEX LIMITED MOLDING DIVISION

Doc. No. : UFL/FR/QA/053

Rev. No. : 00

Rev. Date : 01.11.2019

PRODUCT SPECIFICATION

Product : 10.5mm Cap & Spout

Material Cap: PPCP

Part Weight Cap: 1.10± 0.10gm

Material Spout: HDPE

Part Weight Spout: 2.26± 0.10gm

Masterbatch %: As per Shade Requirement

Product Code Cap: CAPP-10.5

Product Code Spout : SPO-10.5

Product Parameters

S no.	Test Name	Parameter	Standard
1	Cap Dimension Analysis	Cap Height	18.80±0.15mm
		Bottom Outer Diameter	Ø19.50±0.15mm
		Cap ID	Ø14.20±0.05mm
2	Spout Dimension Analysis	Spout Width	Ø16.10+0/-0.40mm
		Inner Diameter	Ø10.50+0/-0.30mm
		Outer Diameter	Ø17.20±0.10mm
3	Tamper Evident Test (For Cap)	Tamper ring should Break	-
4	Leakage Test	Inspection Pressure: 0.25bar Inspection Pressure Tolerance: 0.05bar Filling time: 3 sec Stabilization Time: 3 sec Test time: 3 sec	Pressure Decay upto 70pa allowed
5	Thread Position Deviation Test (For Cap)	Cap to be tightened on Mandrel Guage till stops	±20°
6	Packing	-	Cap-10000pcs per Box Spout-4500pcs per Box

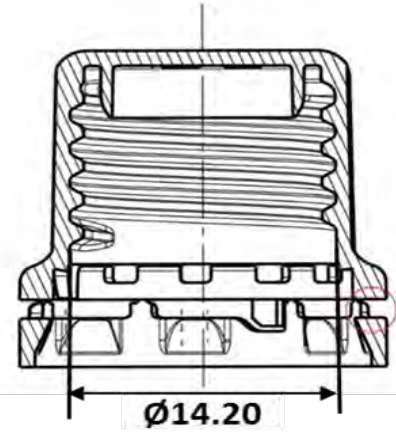
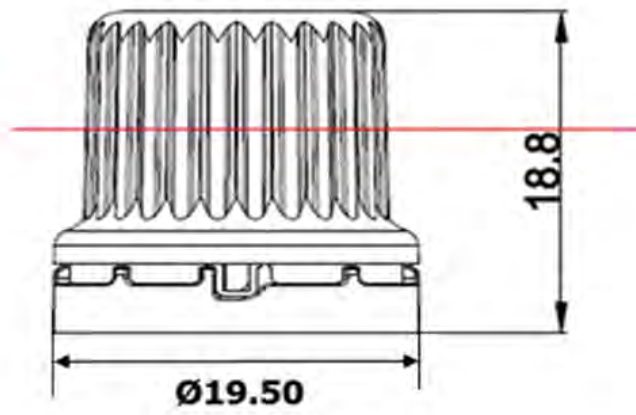

Cap 10.5mm

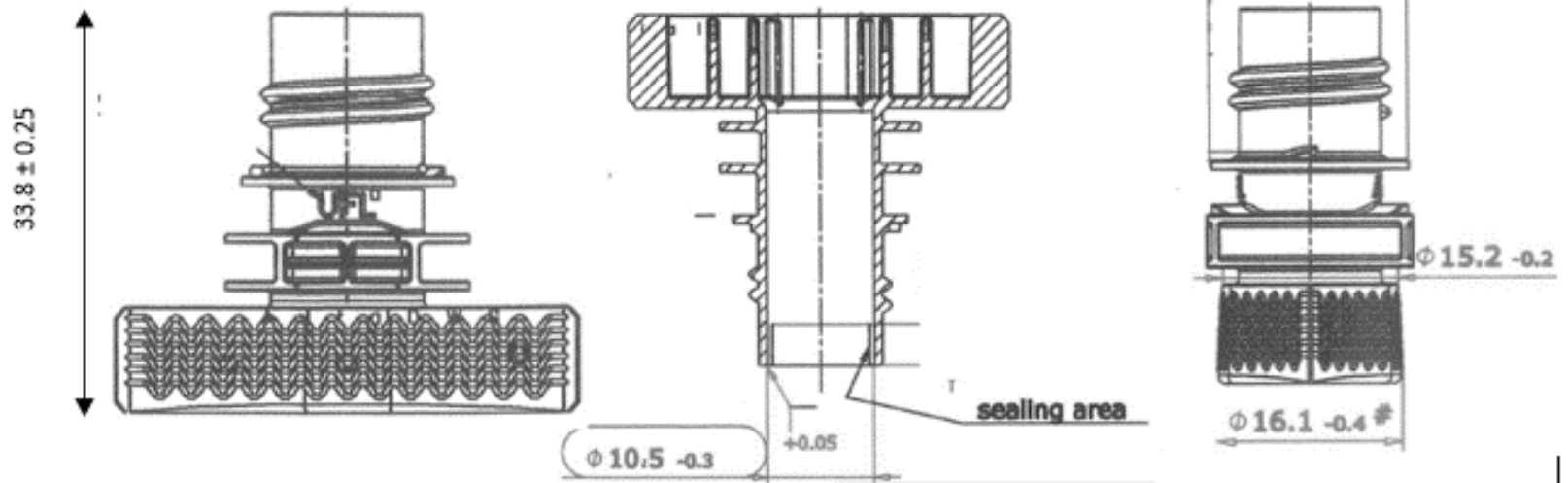

Spout 10.5mm